

**MANUFACTURED FROM FORGED PARTS****MATERIAL:**

- Alloyed carburized steel at chrome-manganese 1.7131 (16MnCr5).

**EXECUTION:**

- Carburized, hardness.  
- Surface hardness HRC 58±2 (670±40 HV30)  
- Depth minimum 0,5 mm.  
- Tensile strength in core minimum 800 N/mm<sup>2</sup> after carburizing.

**ACCURACY:**

- Taper according to DIN 254  
- Taper angle:  
tolerance AT 3 DIN 7178 part 1 and DIN 2080 part 1.  
- Other tolerances according to DIN 7160 and 7168.  
- Taper surface roughness  $R_z < 0,001$  mm.

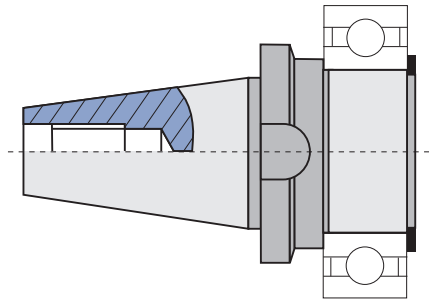
**HERGESTELLT AUS GESCHMIEDETEN TEILEN****MATERIAL:**

- Legierter Aufgekohlter Stahl mit Chrom-Mangan 1.7131 (16MnCr5).

**KONSTRUKTIONS DATEN:**

- Aufgekohlt, gehärtet und angelassen.  
- Oberflächenhärte HRC 58±2 (670±40 HV30).  
- Aufgekohlt auf minimum 0,5 mm Tiefe.  
- Zugfestigkeit im Kern minimum 800 N/mm<sup>2</sup> nach der Aufkohlung.

**GENAUIGKEIT:**

- Dorn nach DIN 254.  
- Kegelwinkel:  
Toleranz AT 3 DIN 7178 Teil 1 und DIN 2080 Teil 1.  
- Andere Toleranzen entsprechend DIN 7160 und 7168.  
- Rauigkeit der Oberfläche  $R_z < 0,001$  mm.

K	AT 3 mm
ISO 30	0,002
ISO 40	0,003
ISO 45	0,003
ISO 50	0,004
ISO 60	0,005

**TOLERANCE AT :**

- Indicates the tolerance of size D surface between the real and the theoretical value of the taper conicity.  
- This value of surface D must always be less (negative), never more (positive) in order to GUARANTEE a good toolholder fixation at the bigger taper diameter.

**TOLERANZ AT :**

- Zeigt die Toleranz auf der Messebene D zwischen dem tatsächlichen Wert der Kegelkonizität und dem theoretischen Wert.  
- Dieser Wert auf der Messebene D sollte immer minus (negativ) sein, nie plus (positiv), um für einen guten Halt des Futter in den größeren Durchmesser des Kegels zu garantieren.

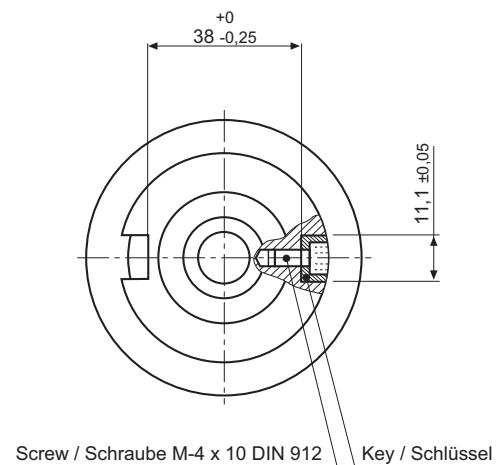
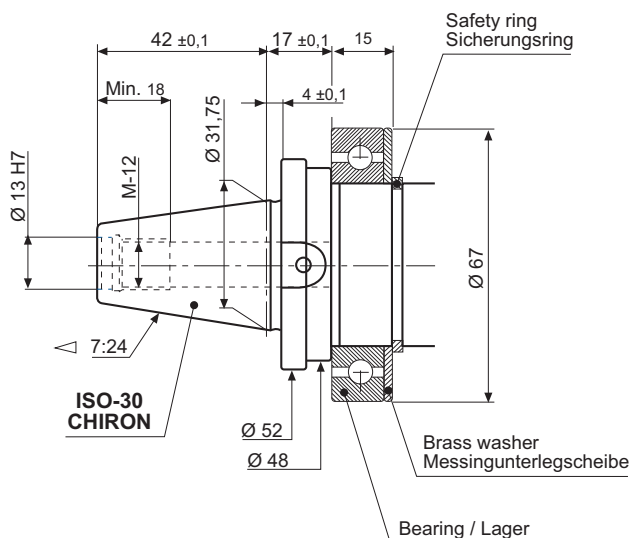
**25 CHIRON**



10  
DIN 208011 13  
DIN 69871-A16  
HSK DIN 69893-117  
TS ISO 26622-118  
PSC ISO 26623-120 23  
JIS B 6339-BT25  
CHIRON

CHIRON

25.160

FRONTAL SHELL MILL ADAPTORS CHIRON





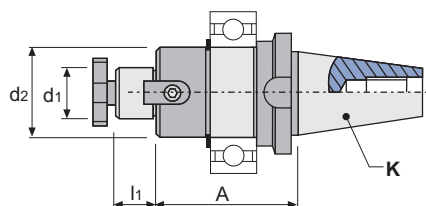

for cutters with driving slot DIN 138

STIRN-AUFSTECKFRÄSDORNE

für Fräser mit Quernut DIN 138



REF.	K ISO	Type / Typ	d <sub>1</sub> h6 mm	A mm	l <sub>1</sub> mm	d <sub>2</sub> mm	kg
25.160.30.16	30	A	16	50	17	39,8	0,800
25.160.30.22		A	22	50	19	39,8	-
25.160.30.27		B	27	50	21	48,0	0,900





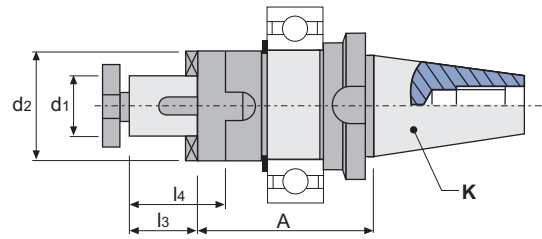

REF.						
25.160.30.16	-	02526	32506	10008	11103	86016
25.160.30.22	-	02526	32506	10010	11004	86022
25.160.30.27	83025	02525	32506	10012	11005	86027

# CHIRON 25.180

**COMBINATION SHELL MILL ADAPTORS CHIRON**  
for cutters with keyway or driving slot DIN 138  
**KOMBI-AUFSTECKFRÄSDORNE CHIRON**  
für Fräser mit Längsnut oder Stirnmitnehmer DIN 138



REF.	K ISO	d <sub>1</sub> h6 mm	A mm	l <sub>3</sub> mm	l <sub>4</sub> mm	d <sub>2</sub> mm	kg
25.180.30.16	30	16	57	17	27	39,8	0,760
25.180.30.22		22	61	19	31	39,8	-
25.180.30.27		27	62	21	33	48,0	0,770

REF.						
25.180.30.16	-	02526	32506	10008	60116	88016
25.180.30.22	-	02526	32506	10010	60122	88022
25.180.30.27	83025	02525	32506	10012	60127	88027

10  
DIN 208011 13  
DIN 69871-A16  
HSK DIN 69893-117  
TS ISO 26622-118  
PSC ISO 26623-120 23  
JIS B 6339-BT25  
CHIRON

CHIRON

25.210

REDUCING ADAPTORS CHIRON



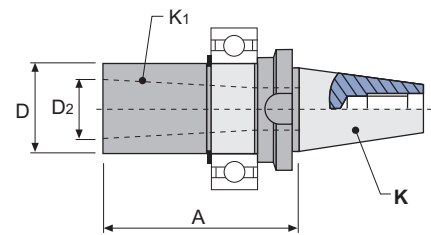

for tools with Morse taper shank and drawbar thread DIN 228-A

REDUZIERHÜLSEN CHIRON

für Werkzeuge mit Morsekegel und Anzugsgewinde DIN 228-A



REF.	K ISO	K <sub>1</sub> MORSE	A mm	D mm	D <sub>2</sub> mm	kg
25.210.30.01	30	1	50	39,8	25	0,620
25.210.30.02		2	65	39,8	32	-
25.210.30.03		3	80	39,8	40	0,780

REF.				
25.210.30.01	16105	19312	32506	11106
25.210.30.02	16105	19315	32506	12110
25.210.30.03	16105	19318	32506	12012

# CHIRON 25.215

## REDUCING ADAPTORS CHIRON

for tools with Morse taper shank and drawbar thread DIN 228-B

## REDUZIERHÜLSEN CHIRON

für Werkzeuge mit Morsekegel und Anzugsgewinde DIN 228-A

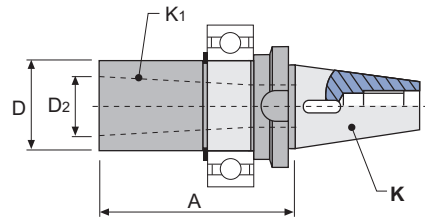

REF.	K ISO	K <sub>1</sub> MORSE	A mm	D mm	D <sub>2</sub> mm	kg
25.215.30.01	30	1	50	39,8	25	0,600
25.215.30.02		2	62	39,8	32	-
25.215.30.03		3	80	39,8	40	0,740

REF.		
25.215.30.01		32506
25.215.30.02		32506
25.215.30.03		32506

25  
CHIRON

BORING HEADS  
BOHRKÖPFE

MORSE SHANKS  
MORSE SCHÄFTE

CYLINDRICAL SHANKS  
ZYLINDRISCHE SCHÄFTE

ACCESSORIES  
ZUBEHÖR

10  
DIN 208011 13  
DIN 69871-A16  
HSK DIN 69893-117  
TS ISO 26622-118  
PSC ISO 26623-120 23  
JIS B 6339-BT25  
CHIRON

CHIRON

25.290



CNC-UNIVERSAL PRECISION DRILL CHUCKS CHIRON

for left and right and turn

UNIVERSALER CHIRON CNC-BOHRFUTTER, GENAUIGKEITSAUSFÜHRUNG

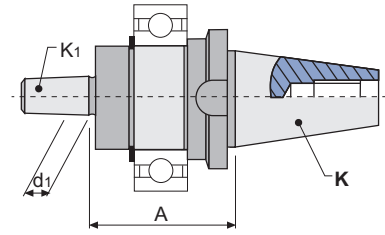
für links- und rechtslaufende Bearbeitungen



REF.	K ISO	K <sub>1</sub> DIN	A mm	d <sub>1</sub> mm		
25.290.30.12	30	B-12	44	12,065	32506	0,630
25.290.30.16		B-16	44	15,733	32506	0,710

REF.	ACCESSORIES / ZUBEHÖR
MU	Standard keyless drill chucks DIN 238 / Standard Schnellspann-Bohrfutter DIN 238
MP	Precision keyless drill chucks DIN 238 / Schnellspann-Bohrfutter DIN 238, Genauigkeitsausführung
MK	Self clamping precision keyless drill chucks DIN 238 / Selbstspann-Bohrfutter DIN 238, Genauigkeitsausführung
MH	CNC-UNIVERSAL precision drill chucks DIN 238 / CNC-Universaler Bohrfutter DIN 238, Genauigkeitsausführung



MU



MP



MK



MH

For more information see page / Für weitere Informationen siehe Seite: K.02, K.03, K.04, K.05

CHIRON  
**25.295**

**SELF CLAMPING SHORT PRECISION DRILL CHUCKS CHIRON**  
for right turn only  
**SELBSTSPANNENDER KURZER CHIRON BOHRFUTTER,**  
**GENAUIGKEITSAUSFÜHRUNG** nur für rechtslaufende Bearbeitungen

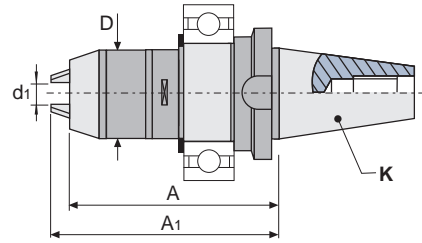

REF.	K ISO	d <sub>1</sub> mm	D mm	A mm	A <sub>1</sub> max mm	Kg
25.295.30.08	30	0 - 8	35,5	83	91	0,880

\* SUPPLIED WITH WRENCH / \* GELIEFERT MIT SCHLÜSSEL

REF.			
25.295.30.08	11206	50008	32506

25  
CHIRON

BORING HEADS  
BOHRKÖPFE

MORSE SHANKS  
MORSE SCHÄFTE

CYLINDRICAL SHANKS  
ZYLINDRISCHE SCHÄFTE

ACCESSORIES  
ZUBEHÖR



10  
DIN 208011 13  
DIN 69871-A16  
HSK DIN 69893-117  
TS ISO 26622-118  
PSC ISO 26623-120 23  
JIS B 6339-BT25  
CHIRON

CHIRON

25.300



WELDON END MILL ADAPTORS CHIRON

for cutters with cylindrical shank and weldon flat DIN 1835-B

CHIRON ZYLINDERSCHAFT-AUFNAHME WELDON

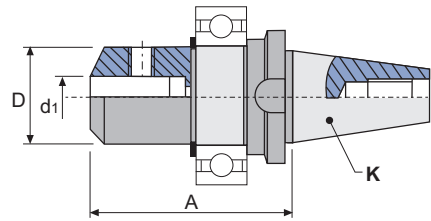
für Fräser mit zylindrischem Schaft und Weldon-Fläche DIN 1835-B



REF.	K ISO	d <sub>1</sub> H4 mm	A mm	D mm			
25.300.30.06	30	6	70	25	32506	15106	0,680
25.300.30.08		8	70	28	32506	15108	-
25.300.30.10		10	70	35	32506	15110	-
25.300.30.12		12	70	40	32506	15212	0,830
25.300.30.14		14	70	40	32506	15212	-
25.300.30.16		16	70	40	32506	15314	0,810
25.300.30.18		18	70	40	32506	15314	0,780
25.300.30.20		20	70	40	32506	15216	0,790

REF.	ACCESSORIES / ZUBEHÖR
42.300	Short and long reducing bushings DIN 1835-B Form A and B / Kurze und lange Reduzierhülsen DIN 1835-B Form A und B
42.311	Short and long reducing bushings DIN 1835-B Form C / Kurze und lange Reduzierhülsen DIN 1835-B Form C



42.300



42.311

For more information see page / Für weitere Informationen siehe Seite: J.11, J.12

CHIRON  
**25.302**



**SHORT END MILL ADAPTORS CHIRON**

for cutters and tooling with cylindrical shank and weldon flat DIN 1835-B

**KURZE CHIRON AUFSTECKFRÄSDORNE**

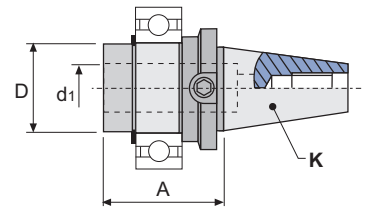
für Fräser und Werkzeuge mit zylindrischem Schaft und Weldon-Fläche DIN 1835-B



REF.	K ISO	d <sub>1</sub> H4 mm	A mm	D mm			
25.302.30.16	30	16	35	32	32506	15114	0,530
25.302.30.20		20	35	36	32506	15014	0,490

REF.	ACCESSORIES / ZUBEHÖR
42.610	Tapping head with axial compensation DIN 1835-B / Gewindefutter, mit Längenausgleich DIN 1835-B
42.620	Quick change tapping head with axial compensation DIN 1835-B+E / Gewindefutter-Schnellwechselfutter mit Längenausgleich DIN 1835-B + E



42.610



42.620

For more information see page / Für weitere Informationen siehe Seite: J.14, J.15

10  
DIN 208011 13  
DIN 69871-A16  
HSK DIN 69893-117  
TS ISO 26622-118  
PSC ISO 26623-120 23  
JIS B 6339-BT25  
CHIRON

CHIRON

25.305

END MILL ADAPTORS TYPE WHISTLE-NOTCH CHIRON



for tools with cylindrical shank and tightening inclined flat DIN 1835-E

CHIRON ZYLINDERSCHAFT-AUFNAHME TYP WHISTLE-NOTCH

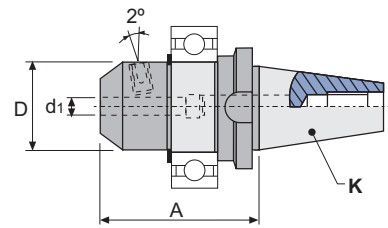
für Werkzeuge mit zylindrischem Schaft und geneigte Spannfläche DIN 1835-E



REF.	K ISO	d <sub>1</sub> H4 mm	A mm	D mm	kg
25.305.30.06	30	6	70	25	0,730
25.305.30.08		8	70	28	0,750
25.305.30.10		10	70	35	0,810
25.305.30.12		12	70	40	-
25.305.30.14		14	70	40	-
25.305.30.16		16	70	40	-
25.305.30.18		18	70	40	0,820

REF.			
25.305.30.06	32506	19005	15106
25.305.30.08	32506	19106	15108
25.305.30.10	32506	19008	15110
25.305.30.12	32506	19110	15212
25.305.30.14	32506	19110	15212
25.305.30.16	32506	19012	15314
25.305.30.18	32506	19012	15314

CHIRON  
**25.353**

**COLLET CHUCKS FOR DIN 6388 (BXX) COLLETS CHIRON**

for tools with cylindrical shank DIN 1835-B

**SPANNZANGENFUTTER FÜR SPANNZANGEN 6388 (BXX)**

für Werkzeuge mit zylindrischem Schaft DIN 1835-B

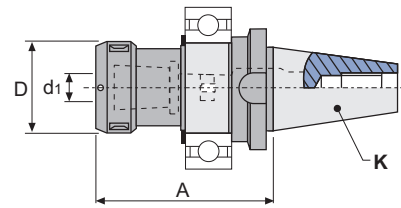

REF.	K ISO	A mm	d1 mm	D mm							
25.353.30.16	30	81	2-16	43	43316	-	-	32506	50116	19216	0,680
25.353.30.25		55	3-25	60	43325	02525	83025	32506	50125	19216	0,710

*\* If you want with ball bearing nut, see page: K.22*  
*\* Wenn Sie diese mit Kugellager-Nute möchten, siehe Seite: K.22*

**\* SUPPLIED WITHOUT WRENCH / \* GELIEFERT OHNE SCHLÜSSEL**

REF.	ACCESSORIES / ZUBEHÖR
BXX	Collets double slot DIN 6388 - Form B / Spannzangen mit Doppelnut DIN 6388 - Form B



**BXX**

For more information see page / Für weitere Informationen siehe Seite: K.10

CHIRON

25.453







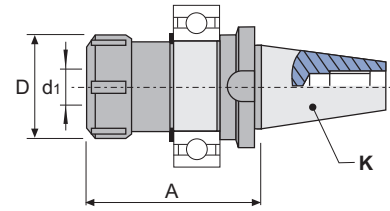

## COLLET CHUCKS FOR DIN 6499 (ER) COLLETS

for tools with cylindrical shank DIN 1835-B

## SPANNZANGENFUTTER FÜR SPANNZANGEN DIN 6499 (ER)

für Werkzeuge mit zylindrischem Schaft DIN 1835-B



REF.	K ISO		A mm	d <sub>1</sub> mm	D mm							
25.453.30.16	30	ER16	55	0,5-10	32	45316	-	-	32506	50216	19210	0,600
25.453.30.16/100		ER16	100	0,5-10	32	45316	-	-	32506	50216	19210	0,720
25.453.30.20		ER20	55	1-13	35	45320	-	-	32506	50220	19212	0,610
25.453.30.20/100		ER20	100	1-13	35	45320	-	-	32506	50220	19212	0,740
25.453.30.25		ER25	55	1-16	42	45325	-	-	32506	50225	19216	0,610
25.453.30.32		ER32	60	2-20	50	45332	-	-	32506	50232	19218	0,840
25.453.30.40		ER40	91	3-26	63	45340	02525	83025	32506	50240	19224	1,100

\* If you want with ball bearing nut, see page: K.22  
 \* Wenn Sie diese mit Kugellager-Nute möchten, siehe Seite: K.22

\* SUPPLIED WITHOUT WRENCH / \* GELIEFERT OHNE SCHLÜSSEL

REF.	ACCESSORIES / ZUBEHÖR
ERXX	Collets double slot DIN 6499 - Form B (ER) / Spannzangen mit Doppelnut DIN 6499 - Form B (ER)
ERCXX	Sealed collets DIN 6499 (ER) / Abgedichtete Spannzangen DIN 6499 (ER)
ERTXX	Collets DIN 6499 - Form Canela (ER) / Spannzangen DIN 6499 - Form Canela (ER)
40.453..	Collet chucks for DIN 6499 (ER) collets / Spannzangenfutter für DIN 6499 (ER) Spannzangen
40.455..	Long collet chucks for DIN 6499 (ER) collets / Lange Spannzangenfutter für DIN 6499 (ER) Spannzangen

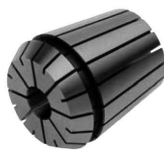

ERXX



ERCXX



ERTXX



40.453..



40.455..

For more information see page / Für weitere Informationen siehe Seite: K.13, K.17, K.19, J.08, J.09



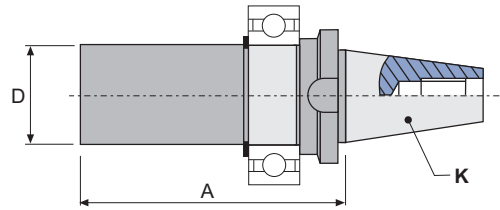

CHIRON  
25.470

BLANK ADAPTORS CHIRON

CHIRON ROHLINGE MIT WEICHEM SCHAFT



REF.	K ISO	D mm	A mm	kg
25.470.30.40	30	40	160	-
25.470.30.60		60	160	3,450

REF.				
25.470.30.40	02526	32506	-	-
25.470.30.60	02525	32506	83025	05525

25  
CHIRON

BORING HEADS  
BOHRKÖPFE

MORSE SHANKS  
MORSE SCHÄFTE

CYLINDRICAL SHANKS  
ZYLINDRISCHE SCHÄFTE

ACCESSORIES  
ZUBEHÖR

CHIRON

25.610





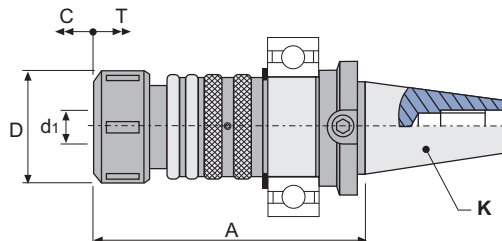

## TAPPING HEAD WITH AXIAL COMPENSATION

hold tape with DIN 6499 (ER) collets and with inner coolant

## GEWINDESCHNEIDFUTTER MIT LÄNGENAUSGLEICH

Befestigung mit Spannzangen 6499 (ER), und mit Innenkühlung



REF.	K ISO		 d <sub>1</sub>	A mm	D mm	C mm	T mm				
25.610.30.16	30	ER16	M3-M12	100	28	7,5	6	45616	32506	50216	-

Compensation in compression (C) and tension (T).  
Compression can be blocked by turning the rear ring (A).  
Control of threading depth.  
Central coolant supply.

Ausgleich der Kompression (C) und der Traktion (T).  
Die Kompression kann mit dem Ring (A) blockiert werden.  
Kontrolle der Gewindetiefe.  
Kühlmittel durch die Mitte.

\* SUPPLIED WITH WRENCH / \* GELIEFERT MIT SCHLÜSSEL

REF.	ACCESSORIES / ZUBEHÖR
ERXX	Collets double slot DIN 6499 - Form B (ER) / Spannzangen mit Doppelnut DIN 6499 - Form B (ER)
ERCXX	Sealed collets DIN 6499 (ER) / Abgedichtete Spannzangen DIN 6499 (ER)
ERTXX	Collets DIN 6499 - Form Canela (ER) / Spannzangen DIN 6499 - Form Canela (ER)
40.453..	Collet chucks for DIN 6499 (ER) collets / Spannzangenfutter für DIN 6499 (ER) Spannzangen
40.455..	Long collet chucks for DIN 6499 (ER) collets / Lange Spannzangenfutter für DIN 6499 (ER) Spannzangen



ERXX



ERCXX



ERTXX



40.453..



40.455..

For more information see page / Für weitere Informationen siehe Seite: K.13, K.17, K.19, J.08, J.09

**1** TYPE / TYP

25.160 	25.180 	25.210 	25.215 	25.290 
25.295 	25.300 	25.302 	25.305 	25.353 
25.453 	25.470 	25.610 		

**2** DIMENSION / ABMESSUNG

**30**

**3** LENGTH (A) / LÄNGE (A)

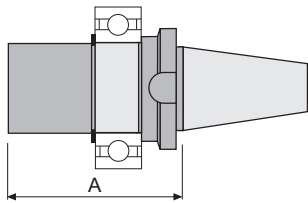

---



---



---



---

**DIAMETER / DURCHMESSER**

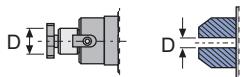

**MK**

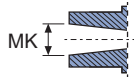

**ISO**

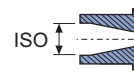

**COLLET  
SPANNZANGE**

NOTES:

---



---



---



---